



ALPHA-260

2 Way Component Speaker System

INSTALLATION MANUAL



www.flux-audio.com

CONGRATULATION

You already bought one of the best FLUX German Car Hifi Component loudspeaker System. Thanks you for deciding to purchase our product. These speaker Systems drivers design to achieve a powerful, high-quality sound, you will get the maximum listening pleasure and ultimate sound reproduction you ever hear.

WARNING

- **ATTENTION**

Please read all the warnings that can be found in this manual. You can install all components in your vehicle and experience an ultimate step by step car audio instalation procedure with proper mechanical and electrical instalations.

- **HEARING DAMAGE**

Continuous, excessive exposure to sound pressure levels in excess of 85dB can cause a loss of hearing. FLUX Components are capable of producing sound pressure levels greater than 85dB.

- **VOLUME AND DRIVER AWARENESS**

Use of sound components can impair your ability to hear necessary traffic sound and may constitute a hazard while driving your vehicle. FLUX except no liability for hearing loss boardly injury or property damage as result of use or missused of this product.

PRODUCT FEATURE

| | |
|--------------------------------|--|
| System | 2 Way Component Speaker |
| Woofer Size & Mounting Depth | 6.5" / 165 mm & 60 mm Mount Depth |
| Woofer Cone/ Dust Cap / Basket | Pressed Paper with Special Coated / Steel basket |
| Power & Impedance | 25W RMS/ 50W Max Power, 3 Ohm Impedance |
| Tweeter V/C Size | 20 mm |
| Tweeter Material | Silk Dome with Special Coat, Aluminium Housing Case Tweeter |
| Passive Crossover | 2 Way passive Crossover separated driver |
| Freq. Resonance (FO) | 70 Hz |
| Mechanical Q (QMS) | 5.87 |
| Electrical Q (QES) | 1.16 |
| Total Q (QTS) | 0.97 |
| SPL 1W / 1 m | 86 dB |

PRODUCT DIMENSION

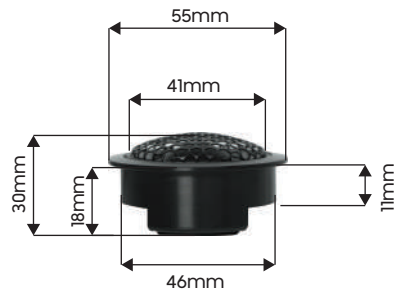

INSTALLATION

It is recommended that your new FLUX speakers be installed by an authorized FLUX Authorized Dealers. This will ensure the use of proper installation techniques and material and will save you a lot of time and efforts.

Do not use your car until all component of the loudspeaker system have been secured to the interior framework. Failure to do so, may cause dangerous to a vehicle flying projectile during a sudden stop or accident,

Do not drill or drive screws through any vehicle interior or carpeted floor before inspecting the underside for potential punctures to control lines or cables. Take extreme care when working near the fuel tank, gas lines brakes or hydraulic lines and electrical wiring,

Turn off the audio system. It is also advisable to disconnect the negative (-) terminal of your vehicle battery whenever performing installation work. If the installation finished turn on the various components and slowly advance the volume.

Remember to check and re-check all connections to insure proper installation and use.

Do not exceed the indicated maximum operational power.

Please make sure the same polarity in loudspeaker, crossover and amplifier are guaranteed. if speakers are wired out of phase, an unnatural sound without bass is the result.

POSITIONING

Using a component speaker gives you the freedom to place the woofer and tweeter separately in your car. It could be good or bad in terms of sound quality, it depends where you put it.

2 Way Speaker System

2 way speaker system tweeter and midbass drivers are supported, commonly tweeter positioned on the dashboard in the A pillars, while the midbass in the doortrim or placed under the door panels because the size are big enough. Placement on the pillar A tweeters did not take place on the dashboard and relatively unobtrusive view. This system is most commonly used, because these systems are the simplest.

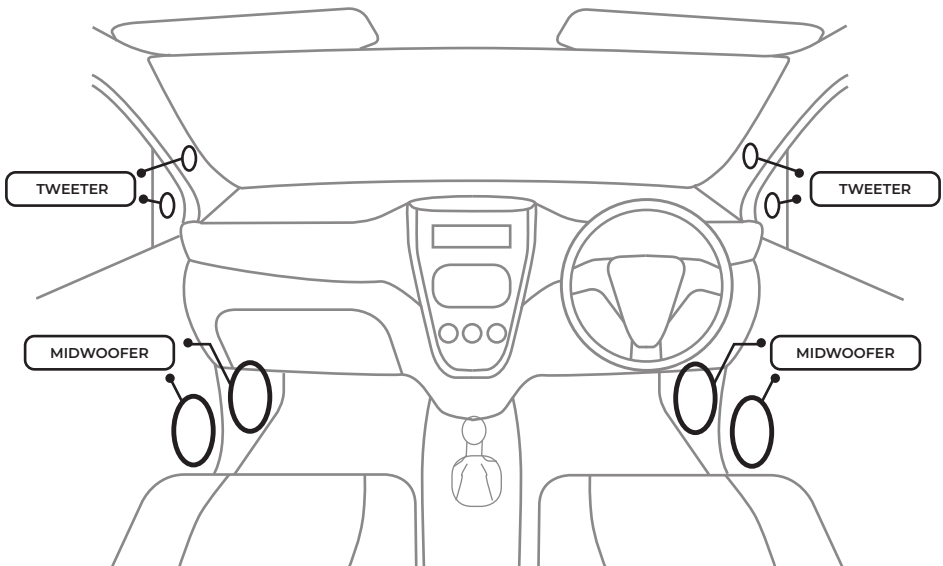

CONNECTING THE COMPONENT

2 Channel Amplifier

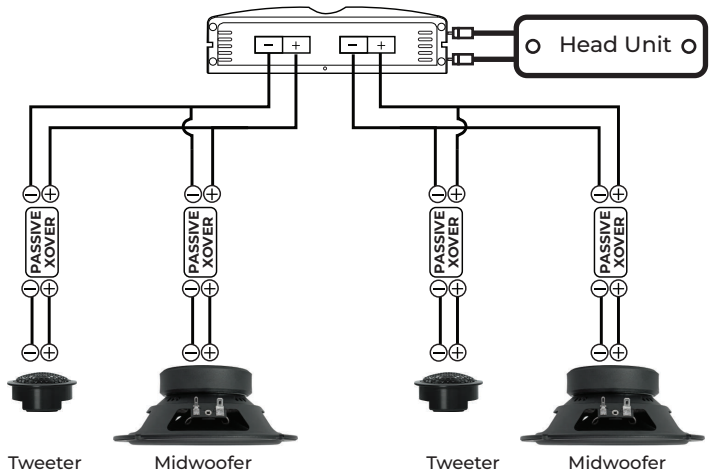

4 Channel Amplifier

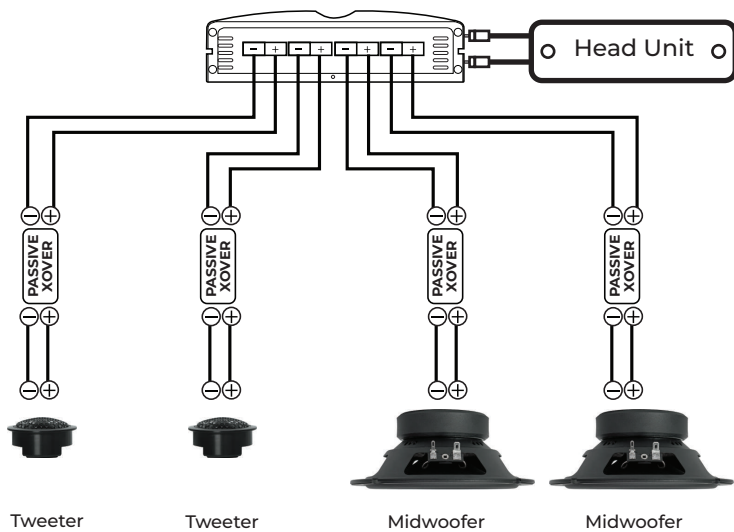

RUNNING IN PERIOD / BREAK IN

To ensure such complex mechanical elements work in harmony with each other, they must be allowed to function correctly in this environment. Such change in temperature and humidity are regarded as very hostile. For speakers to benefit, a running-in period must be used to ensure they are prepared for this. We recommend that once the system is ready for listening the drive units should be run-in with medium volume setting, with music that has the full bandwidths of frequencies. This running-in period should be minimal 24 hours and for full potential should be a few weeks, after which the excellent performance of your system can be fully appreciated.



ALPHA

S E R I E S



 LIKE US!

www.flux-audio.com